

Brushless DC Motor

39RBL SERIES

● INDICATIONS OF THE MODELS

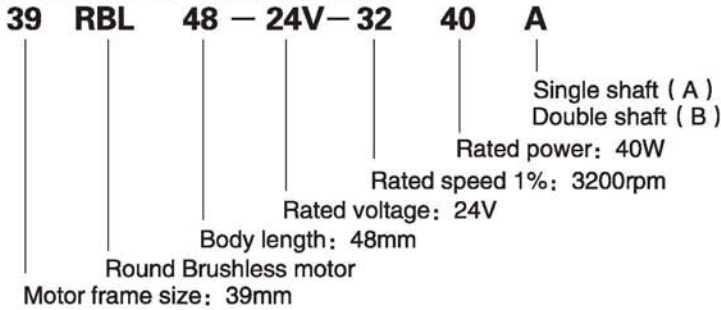

● GENERAL SPECIFICATIONS

Winding type	Star
Hall effect angle	120degree electrical angle
Shaft run out	0.025mm
Radial play	0.02mm@450g
End play	0.08mm@450g
Max. radial force	15N @ 10mm from the flange
Max. axial force	10N
Insulation class	Class B/F
Dielectric strength	500VAC, 1 min.
Insulation resistance	100MΩ, 500VDC

● ELECTRIC CONNECTION

Lead No.	Lead Color	Lead Gauge	FUNCTION	DESCRIPTION
1	Red	UL1430 AWG26	Vcc	HALL positive:+5→+24V
2	Blue		Hall U	
3	Green		Hall V	
4	White		Hall W	
5	Black	UL1430 AWG18/20/ 22	GND	HALL negative
6	Yellow		U	
7	Red		V	
8	Black		W	

● ELECTRICAL SPECIFICATIONS

	Unit	39RBL48-24V-3240A
Number of poles		6
Number of phase		3
Rated voltage	VDC	24
Rated speed	RPM	3200
Continuous running torque	mN.m	132
Rated torque	mN.m	110
Rated power	W	40
Peak torque	mN.m	330
Peak current	A	6
Line to line resistance	ohms@20°C	1.3
Line to line inductance	mH	0.8
Torque constant	mNm/A	58.7
Back E.M.F	Vrms/KRPM	4.35
Rotor inertia	g.cm ²	40
Body length(L)	mm	48
Weight	Kg	0.35

● DIMENSIONS

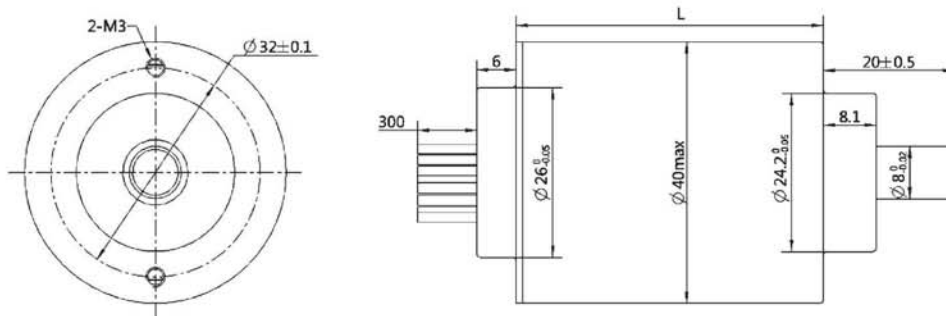

*Product developing, only available for samples.