

Brushless DC Motor

86BLC SERIES

● INDICATIONS OF THE MODELS

86 BLC 64

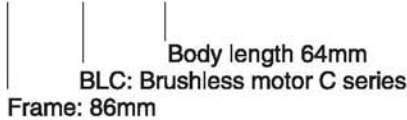

● GENERAL SPECIFICATIONS

Winding type	Star
Hall effect angle	120 degree electrical angle
Shaft run out	0.05mm
Radial play	0.02mm@450g
End play	0.08mm@400g
Max. radial force	220N@20mm from the flange
Max. axial force	45N
Insulation class	Class B
Dielectric strength	500VAC for one minute
Insulation resistance	100MΩ, 500VDC

● ELECTRIC CONNECTION

Lead No.	Lead Color	Lead Gauge	FUNCTION	DESCRIPTION
1	Red	UL1332 AWG26	Vcc	Power supply positive of Hall +5VDC~+24VDC
2	Blue		Hall A	
3	Green		Hall B	
4	White		Hall C	
5	Black	UL1332 AWG14	GND	Power supply negative of Hall
6	Yellow		U	
7	Red		V	
8	Black		W	

● ELECTRICAL SPECIFICATIONS

Model	Unit	86BLC64	86BLC77	86BLC105	86BLC125
Number of poles		8			
Number of phase		3			
Rated voltage	VDC	48			
Rated speed	RPM	3000			
Rated torque	N.m	0.4	0.8	1.6	2.22
Rated power	W	130	250	500	700
Peak torque	N.m	1.2	2.4	4.8	6.66
Peak current	A	11	17.5	37	52
Line to line resistance	ohms@20°C	1	0.34	0.14	0.1
Line to line inductance	mH	1.4	0.6	0.36	0.24
Torque constant	Nm/A	0.122	0.149	0.135	0.131
Back E.M.F	Vrms/Krpm	9	11	10	9.7
Rotor inertia	g.cm ²	400	800	1600	2400
Body length(L)	mm	64	77	105	125
Weight	Kg	1.5	1.85	2.7	4

● DIMENSIONS

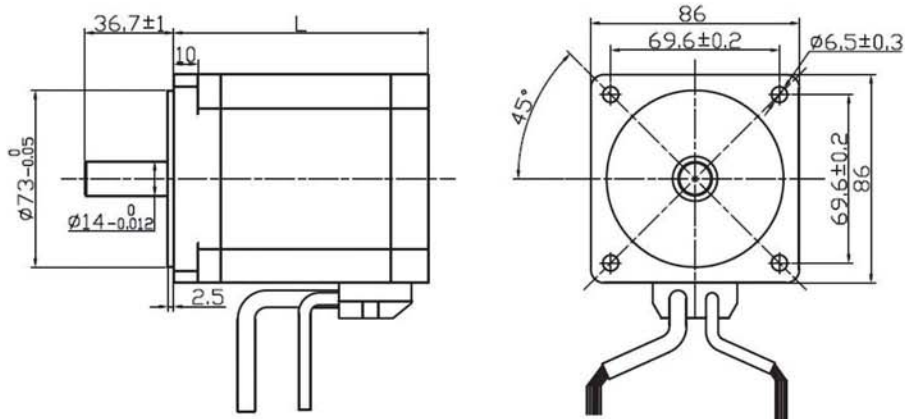

*This motor can be designed & manufactured with customized request.